

## **FOREWORD:**

Thanks for your purchasing this motorcycle.

With the help of this manual, you will learn the correct procedures of operation and basic knowledge of maintenance and trouble shooting of the motorcycle. It presents all the basic knowledge of maintenance and trouble shooting of the motorcycle. It presents all the details of the performance of this motorcycle to you and the vehicle will make your life more relaxed and happier.

In case any picture does not agree with the vehicle physically, the latter shall prevail.

**CAUTION. NOTE and MAIN POINTS** carry special meanings and should be carefully reviewed.

**!CAUTION:** The personal safety of the rider may be involved, disregarding this information could result in injury to the rider.

**NOTE:** These instructions point out special service procedures or precautions that must be followed to avoid damaging the machine.

**MAIN POINTS:** This provides special information to make maintenance easier or important instructions clearer.

## **VIN AND ENGINE SERIAL NUMBER LOCATION**

The VIN and/or engine serial number are used to register the motorcycle. They are also use to assist your dealer when ordering parts or special service information.



The VIN is stamped on the front main beam of the frame.

The engine serial number is stamped on the rear end of the crankcase assembly

**VIN. :**

**Engine No.:**

## **CONTENTS**

NOTES FOR SAFE RIDING.....2

LOCATION OF PARTS.....4

INSTRUMENT PANEL.....7

USING METHODS OF SWITCHES.....8

USING METHODS OF TRUNK.....10

ADD GASOLINE AND ENGINE OIL.....11

CORRECT DRIVING OPERATIONS.....12

INSPECTION BEFORE RIDING.....20

PERIODICAL INSPECTIONS.....23

SIMPLE MAINTENANCE METHODS ..... 26

SPECIFICATIONS..... 30

ELECTRICAL DIAGRAM.....31

**NOTES FOR SAFE RIDING**

**RIDING APPAREL**

1. Loose, fancy clothing can be uncomfortable and unsafe when riding your motorcycle. Choose good quality

motorcycle riding apparel when riding your motorcycle.  
 2. most motorcycle accident fatalities are due to head injuries. ALWAYS wear a helmet, a face shield or goggles as well as boots, gloves and protective clothing. so does the passenger on your motorcycle.  
 3. the exhaust system must be very hot while you are riding, and even remains so after the engine operation stops, so never touch any part of the hot exhaust

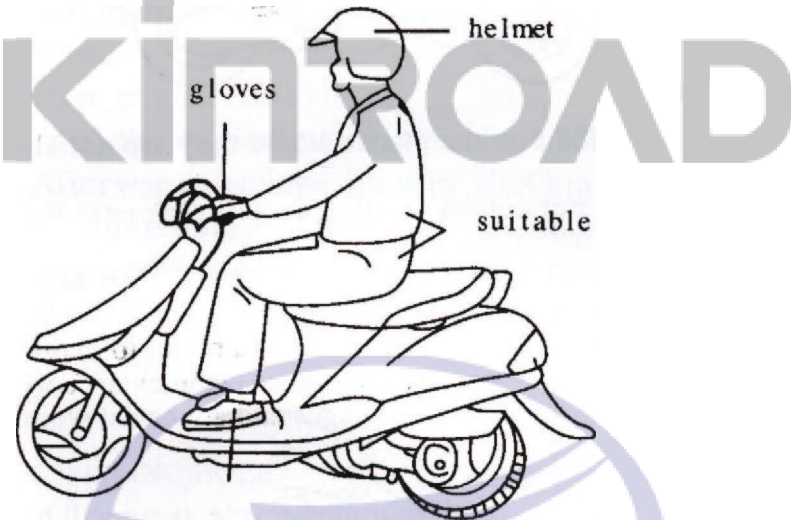

## RULES FOR SAFE DRIVE

Check must be conducted before starting the engine to prevent mishaps and damage to components.

Only the qualified person who has passed the drive examination with a drive license is permitted to drive the vehicle but not anybody else without a drive license.

Full preoccupation is required during drive, paying attention to the following points to avoid any possible hurt to you by other motorized vehicles:

Do not drive too close to other vehicles;

Never contend for lane.

Strictly observe the local traffic rules.

As driving at overspeed is the cause of many accidents. Do not drive at a speed that the actual situation does not permit.

Particular care should be exercised at the level crossing of roads, entrance and exit of parking lot or on the automobile lane.

During drive, grasp the left handlebar by the left hand and the throttle twist grip by the right hand, with feet on the footrests.

## MODIFICATION

any modification of the motorcycle or removal of the

original equipment may render the vehicle unsafe or illegal. Please obey all the national and local equipment regulations.

## DO NOT OVERLOAD

1. Do not load on the places where they are not allowed.
2. Do not put cotton or other same items near the engine or the exhaust pipe, When the motorcycle is in the over-loading condition, its stability, security and speed will be affected.



*LOCATION OF PARTS*





rear brake lever

handle bar

front turn signal  
front lamp

trunk

seat lock

front wheel

side stand

kick starter

rear wheel



1. Ignition switch/stolen-prevention lock
2. Electric starter switch
3. Lamp switch
4. Handlebar
5. Front brake lever
6. Right mirror
7. Fuel level indicator
8. The turn signals
9. speedometer
10. Left mirror
11. Switch to change the far and near light
12. Rear brake lever
13. Turn signals switch
14. Horn button

KINROAD KINROAD

## ***INSTRUMENT PANEL***

### **HOW TO USE THE INSTRUMENT PANEL**



#### **① SPEEDOMETER**

The speedometer indicates the road speed in kilometers per hour.

#### **② ODOMETER**

The odometer registers the total distance that the motorcycle has been run (The minimum number is 0.1km) You should change the engine oil and check the motorcycle periodically according to it.

#### **③ FUEL GAUGE**

The ‘ ‘E’ ’ mark indicates the fuel tank is empty or nearly so.

### **MAIN POINTS**

1. The indicator will stop at E position when the ignition switch is turned to OFF position.
2. place the motorcycle on the center stand to read the number of the left fuel.

#### **④ THE TURN SIGNALS**

Turn the switch to “LEFT” or “RIGHT” position, the turn signal will flash to advise the driver.

#### **⑤ THE FAR LIGHT INDICATOR**

The indicator will be lit when the change light switch turned to FAR LIGHT position.

## ***USING METHODS OF THE SWITCHES***

### **THE IGNITION SWITCH**

The ignition switch control the start, the wiring diagram for lights and the lock for the handlebars.

Please take the key with you when you leave your motorcycle.

(ON)it is connected.

- 1.You can start the engine.
- 2.You can drive
- 3.You can not take the key down

(OFF)it is shut down.

1 • You can not start the engine.

2 • The engine is stopped.

3 • You can take the key down or put the key in .

(LOCK)it is locked.

1.The handlebar are locked , you cannot change directions.

2.You can take the key down or put the key in.

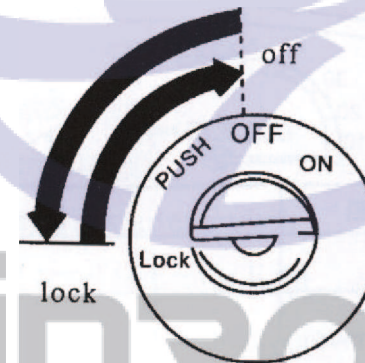

### **THE KEY TO THE HANDLE BARS**

Please lock the handlebar lock when you leave the motorcycle to avoid to avoid to be stolen.

(1)turn the handlebar to the left

(2)put the key in from OFF position, press and turn to LOCK position.

(3)take the key down.

Do not press when you want to open the lock, it will be all right to turn the key, from LOCK position to OFF Position.



## MAIN POINTS

1. If it is hard to lock, you can turn the handlebar to the right a little and then lock it.
2. Shake the handlebars left and right to be sure that it has been locked.

## THE TURN SIGNALS



Use the turn signals when you want to turn to the left or the right.

R: the right turn signal will flash.

L: the left turn signal will flash.

MIDDLE: the turn signal will not flash.

After you have finished, please turn off the turn signals.

## THE HORN BUTTON

Press the horn button, the horn will loud.

## MAIN POINTS

Do not use the horn if unnecessary.

## THE CHANGEABLE SWITCH FOR

### THE FRONT LIGHT

Use this switch, you can change the light direction of the front lamp.

HI: the high beam

LO: the low beam

## MAIN POINTS

When there are cars before you or coming towards you in the night, please use the LO switch.

## THE START SWITCH

This Switch is to start the engine

Turn the switch to ON position and squeeze the brake lever. meanwhile press the starting button and the engine will be started.

## NOTE

If the engine call not be started in 3 seconds, please use the kick starter to stare the engine to avoid emptying the battery. Then check the starting system.

## THE FRONT LAMP SWITCH

Light switch

The front light switch has three positions,

 And “●” (a white point).

 When the switch is in this position, the front head light, tail and meter lights are all lit up.

 When the switch is in this position, the tail, betraying and meter Lights are lit up.

“●” When it is in this position. The front illuminator, tail, betraying and meter lights are all

## MAIN POINTS

After the engine is started by pressing the ignition switch, you can inspect the wiring diagram for the lights.

## USING METHODS OF THE TRUNK



off.

## OPEN THE TRUNK

Open the seat when you want use the trunk or put the helmet in it.

1. put the ignition key in the lock of the seat and turn to the right.

2. Hold the seat from the back up and open the seat.

3. Press the seat and the lock will be closed automatically.

## NOTE

1. Hold the seat up slightly to see if the lock is closed.

2. If you press the seat when the ignition key in the trunk, you can not take the key out, so please pay much attention to this.

3. Do not keep such items as cotton on any place under the seat except the trunk.

## MAIN POINTS

1. The trunk load capacity is 10kg.
2. Do not keep heat-sensitive items in trunk when the trunk may get hot.
3. Do not keep valuable and easily damaged items in the trunk.
4. Keep the easily-flown items first in the plastic bag then put them in the trunk.
5. Do not allow water to get inside when the washing the motorcycle.
6. Do not clean the trunk with water.

## ADD GASOLINE AND ENGINE OIL

### ADD GASOLINE

There is a gasoline tank gate at the rear part of the seat, open it with the ignition key, take down the cover. add unleaded gasoline with an octane rating of 90 or higher.

### ENGINE OIL

There are several reasonable effects included in the engine oil with high quality. only the high degreasing 4-stroke SAE10W-30 (SIGMA) engine oil can ensure this requirement or even exceed it. Do not need to use other additives. You can use the HQB-10 engine

oil instead according to the condition of our marketing service.

**Mucosity:** The mucosity of engine oil is to be decided according to the humidity of local climate.

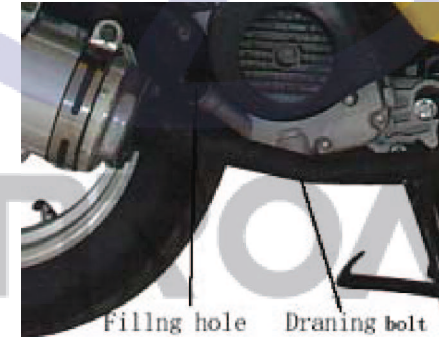

### CHANGE

### ENGINE OIL

Change the engine oil after the first 300km riding. Afterwards, change it every 1000km, check the volume every 500km riding and add it to the standard volume in time. The full volume is 0.9L and the replace volume is 0.75L.

### CHANGE GEAR OIL

Change the gear oil after the first 300km and every 5000km successively or every half a year, whichever comes first. check the capacity every 500km. pls use SAE80W90 gear oil.

The volume of the



Draining bolt  
of gear oil

Filling hole  
of gear oil

gear oil  
Full volume. 0.11L



KINROAD



KINROAD



KINROAD



KINROAD

### **NOTE**

1. Don't fill oil prior to the FULL level when adding oil.
2. The engine will be easily damaged when driving without oil.
3. Don't mix oil with other type of oil and it will affect the performance of the engine.
4. Wipe off the oil outside the engine.
5. Close the cover of the oil tank.
6. Don't put cotton on the oil tank to avoid keeping the oil back or damaging the engine.

### **! CAUTION**

Please pay much attention to the following items when Adding gasoline or oil to the engine.

1. Shut off the engine and turn the ignition switch to OFF.
  2. Fire is forbidden and do not add oil beside fire and smoke.
  3. Add gasoline or oil on a flat place.
  4. Don't add gasoline too much to avoid it coming out.
  5. Don't make dirt into the gasoline tank.
  6. Close the cover of the oil tank.
  7. Wipe off the gasoline outside the gasoline tank.
- Forbid to store gasoline at home since it is very dangerous.

## ***CORRECT DRIVING OPERATIONS***

### **STARTING METHOD OF THE ENGINE**

#### **BEFORE STARTING**

1. You must check the volume of oil and gasoline.
2. Place the motorcycle on the center stand.
3. Start the engine at left side of the motorcycle.

[1] Turn the ignition switch to ON position  
Please inspect the motorcycle according to the following items:

1. If the ignition switch has been on ON position.
2. Inspect if the front lamp and the rear lamp lit or not.
3. If all the switches are functional or not.
4. If the horn is functional when pressing the horn button.
5. If the horn is un-functional. perhaps the fuse is broken, Please refer to page 33

After you have done the above inspections, please go to dealer's service station if the lights or the horn are still un-functional.



[2] Hold the front and rear levers



### MAIN POINTS

The electric start will be un-functional if the brake levers are not squeezed.

[3] Don't rotate the throttle handlebar when pressing the start button.



### MAIN POINTS

1. After the engine is ignited, please release the start button to avoid affecting the engine.

2. To avoid empty the battery, please use the kick starter to start the engine after 3 seconds by the electric start or and then check the starting system.

3. Please rotate the throttle handlebar 1/8-1/4 round and then start the engine again if you can not ignite the engine 2 or 3 times. Return the throttle handlebar after ignition.

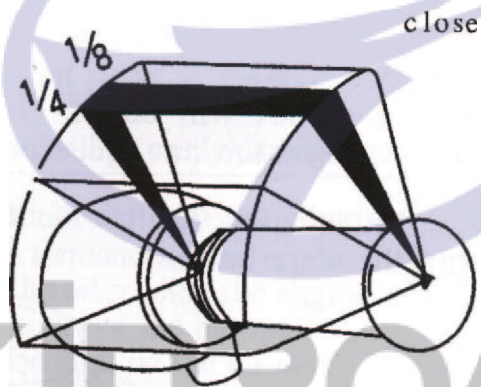

[4] Preheat the engine while it is cool.

### **! CAUTION**

Don't preheat the engine in a close room because of the noxious gas such as CO in the waste gas.

### **MAIN POINTS**

1. If the engine is cool, warm it after it is started.

2. The engine will be difficultly started when the fuel runs out and added again or it has been stored for a long time. At this time do not rotate the throttle bar and start the engine for several times. (recommend starting by the kick starter). After the gasoline is burnt, water will be produced and leave in the exhaust pipe. so in the cold areas, note the problem of water becoming ice.

When the battery is out and can not start by the electric starter

First confirm the following items then start again.

[1] Turn the ignition switch to ON position.

[2] Hold the rear brake lever with the left hand and press the front part of the seat with the right hand.

[3] Kick the kick starter with the right foot.



Know well about the correct driving way.

It is good not only for security, but also for the using life of your motorcycle. saving fuel and oil.

## **METHOD OF STARTING**

### **[1]RELEASE THE CENTER STAND**

After starting the engine , hold the rear brake lever with left Hand and push the motorcycle for ward with the right hand to release the center stand.

#### **NOTE**

Please hold the back dress holder when you release or place the Center stand. do not hold the back part of the seat.

### **[2]THE PROCEDURE TO DRIVE MOTORCYCLE**

Hold the handlebars with both hands, sit on the seat from the left. At this time. The left foot stand on the ground squeeze the rear brake lever.

#### **NOTE**

Don' t rotate the throttle handle bar before starting.

### **[3] OBSERVE IF THE SURROUNDING IS SAFE**

Before starting, you should give on information using the left turning signal to observe if the surroundings is safe or not. Squeeze the rear brake at this time.





**NOTE**

Note the cars from the back.

**[4] START**

Loosen the brakes and rotate the handlebar of throttle to make the motorcycle start gradually.



**NOTE**

If rotate the handlebar Of throttle too much , it may make the motorcyle run for-ward suddenly.

**ADJUST SPEED**

Adjust speed through rotating the handlebar of throttle.

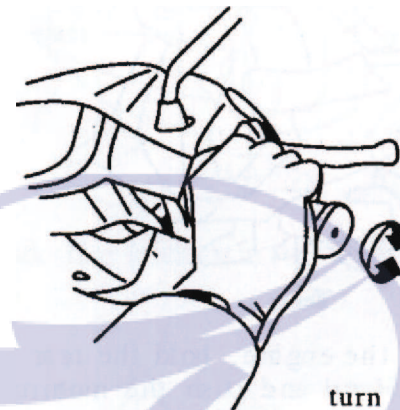

Rotate accelerate, it is better to rotate slowly  
Return, It is better to return quickly

**USING METHOD OF THE BRAKES**

It is better to use the front and rear brake together.



1. Squeeze the brake levers after quick returning the throttle bar.
2. Gradually shut the motorcycle and make the speed low is the most proper way to use the brakes.

### **NOTE**

It is very dangerous if use only the front brake or the rear brake. It may make the motorcycle slip.

### **DON' T BRAKE OR TURN SUDDENLY**

It is extremely dangerous to brake or turn in a sudden, it may make the motorcycle slip or turn over

### **BE EXTRA SAFETY CONSCIOUS ON BAD WEATHER DAYS**

Riding on bad weather days, especially wet ones

requires extra Caution. Braking distance double on a rainy day. Stay off of the painted surface marks, manhole covers and greasy appearing areas as they can be especially slippery. Use extreme Caution at railway crossings and on metal gratings and bridges. Whenever in doubt about road conditions, slow down!

### **PAY ATTENTION TO WORKING CONDITION OF THE BRAKES AFTER WASHING OR DRIVING IN WATER**

The function Of the brake will be affected after washing or driving in water. Drive slowly until the brake become normal.

### **CORRECT WAY TO PARK THE MOTORCYCLE**

#### **[1]give signals**

First use the turn signals to inform others and then drive to the sides of the road.

Return the throttle and squeeze the front and rear brake levers. At the same time, the brake indicator is lit to inform the following drivers.

[2] Turn the ignition key to OFF position .



Shut off the turn signals and turn the ignition key to OFF position after parking well the motorcycle.

[3] Place the motor cycle on the center stand

place the motorcycle on the center stand on the place where does not affect traffic .

1. Hold the handlebar with the left hand and hold the tail part with the right hand.

2. Press the lever of the center sand with the right foot and take the motorcycle up with the right hand.



**NOTE**

Don' t park the motorcycle on the soft ground or on a slope.

[4] Lock the turning bar

To avoid stolen. Please lock the steering and bring the key with you when you leave.

## BREAK IN

Proper break-in is important to achieve maximum life and performance from your motorcycle.

1. The first month or the first 1000 km drive with in 45km / h.
2. Avoid unnecessary accelerating suddenly.



### !CAUTION

Don' t allow to drive with single hand or both hands free, don' t allow to load goods or children on the footrest. Obey the safe speed and remember safe driving.

Check the following items before going to service station.

The engine can not be started?

Check the following items again:

1. If there is fuel in the engine?
2. Turn the ignition switch to ON position.
3. Press the starting button while squeezing the brake levers.

Control the bars while turning the throttle.

Re-start the engine after you have confirmed the above items.

## THE START ENGINE UN-ROTATE

Press the button, if the start engine does not rotate. check:

1. If the ignition switch is in the ON position?
2. Press the start button mean while squeezing the front or the rear brake ,if it is still not started.
3. Turn the ignition switch to ON position and press the horn button, if the horn has no noise to see if the capacity of the battery is not enough

## THE ENGINE IS OFF WHILE DRIVING

Please check the following items;

1. Is there fuel?

If there is no fuel in the fuel tank, go to the nearby gas station to add fuel to the engine.

After you have committed the above items, start the engine again in the way of page 15.

2. If the engine can still not be started, go to service station.

## INSPECT BEFORE DRIVING

To ensure you drive the motorcycle safely and comfortably. Please obey the traffic regulations and inspect periodically every 6 months and 12 months and check every day before driving.

### **!CAUTION**

1. If you feel the motorcycle is abnormal, consult the service station.

2. Don't forget to inspect it periodically while storage.

3. Careful inspections should be done after storage.

## PAY ATTENTION TO SECURITY WHILE INSPECTING

### **NOTE**

1. Place the motorcycle on the center stand on a wide and flat place.

2. Avoid hurting from the heat of engine and exhaust pipe.

3. If you inspect the drive performance, drive in a safe place while paying attention to the surroundings.

## INSPECTION ITEMS BEFORE DRIVING

The driver should do the inspection before driving every day.

1. The abnormal parts from the last day, the function of the brakes and the play between the brake levers.

2. Check the tyre pressure and cracks, damages, abnormal wearing, if there are metal, stones and glass in the tyres.

3. The depth of the threads;

4. The oil in the engine;

5. The fuel;

6. The lights and the turn signals

7. The pictures in the mirrors;

8. Dirt or damages of the mirrors and the brand.

## CHECK THE ABNORMAL PARTS FROM THE LAST DAY

Check the abnormal parts that you have found from the last day while driving to see if they will affect

driving the motorcycle.

### CHECK THE FUNCTION OF THE BRAKES

Squeeze the brake levers to see if the play is between the standardized limits.

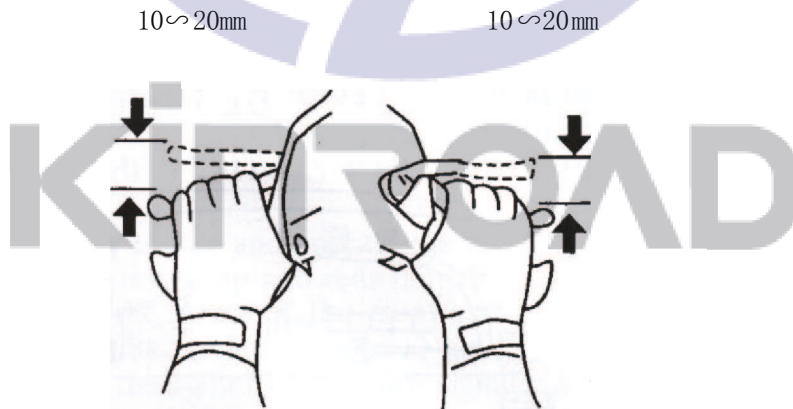

### CHECK THE TIRES

the pressure of the tires  
observe the part of the tires where touch the ground to see if the pressure is normal. If it is abnormal, check and adjust it by using the pressure gauge

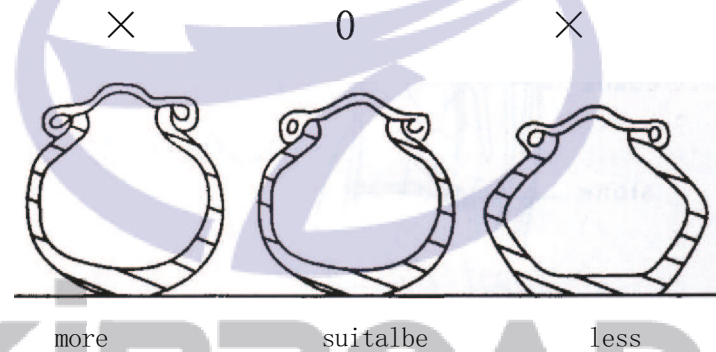

### !CAUTION

The abnormal tire pressure and tire crack & damages and abnormal wearing are the main causes to make unfunctional turning and explode the tires.

Replace the tire when the tread depth is less than 1mm

Replace the tire when crack or scratch occurs

### CHECK IF THE FUEL IS ENOUGH TO DRIVE TO DESTINATION

Turn the ignition to switch to ON position, if the indicator is before E, please add fuel to your motorcycle.

## CHECK LUBRICANT OF THE ENGINE

Turn the ignition switch to ON position to see if the oil indicator lit or not, if it is lit, please add Lubricant oil to the engine.



### **!CAUTION**

Don't make lubricant oil in the engine run off other - wise the engine will be damaged while driving.

## CHECK THE LAMP AND THE TURN SIGNALS

1. Start the engine and operate the lighting switch to see if the front lamp and rear lamp are lit or not.
2. operate the levers of the front and rear brakes to see if the brake indicator is lit or not.
3. operate the switch of the turn signals to the

left or the right signals are normal or not.

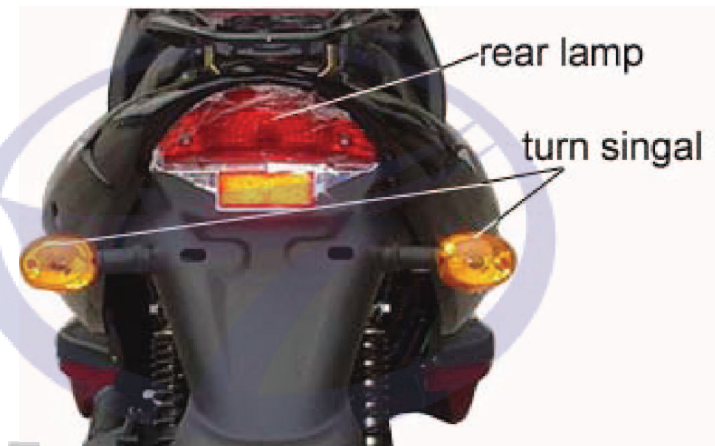

## CHECK THE MIRRORS

Check the mirrors by sitting on the seat to see if

you can clearly see the back and side part from the mirrors.

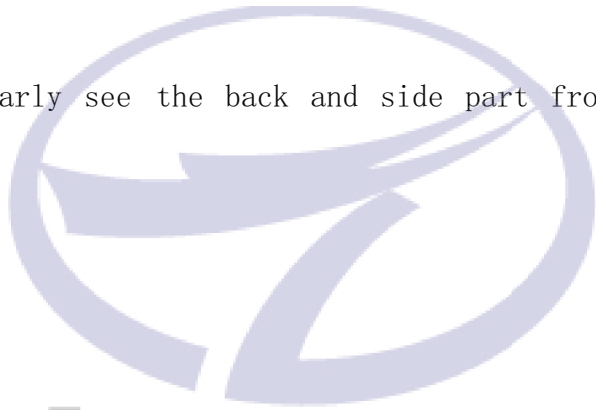

KINROAD



KINROAD



KINROAD



KINROAD





## ***PERIODICAL INSPECTION***

Periodical inspections are done by the riders themselves, they are divided into 6 monthly and 12 monthly inspections.

There are two sections: A section and B section in 6-monthly inspections.

A section: If you have basic knowledge of motorcycles, you can do the inspections by yourselves.

B section: To do the inspections in this section, you need special technical knowledge and special tools. You can entrust the service station to do such inspections.

## **! CAUTION**

1. Pay much attention to security while inspecting.
2. Place the motorcycle on the center stand on a wide and flat place.
3. Avoid hurting from the heat of engine and exhaust pipe.
4. Don't start the engine in a close room because of the noxious gas from starting the engine.
5. If you inspect the drive performance drive in a safe place while paying attention to the surroundings.
6. If you have found it abnormal. Drive it after you have solved the problems. bars up and down.

## **CHECK THE OPERATION PART**

Check if the front fork is bent or damaged. Check if there is abnormal noises while shaking the handle bars up and down.

If the front fork is abnormal, consult KINROAD service station.

## **CHECK THE BRAKES**

The rear and front brake lever play

After adjusting the play, check that there is no dragging when turning rear wheel with the wheel off the ground and that there is enough clearance between the rear brake lever and grip when the lever is tightly squeezed

The rear and front brake lever play measured at the end of the levers should be 10-20mm.

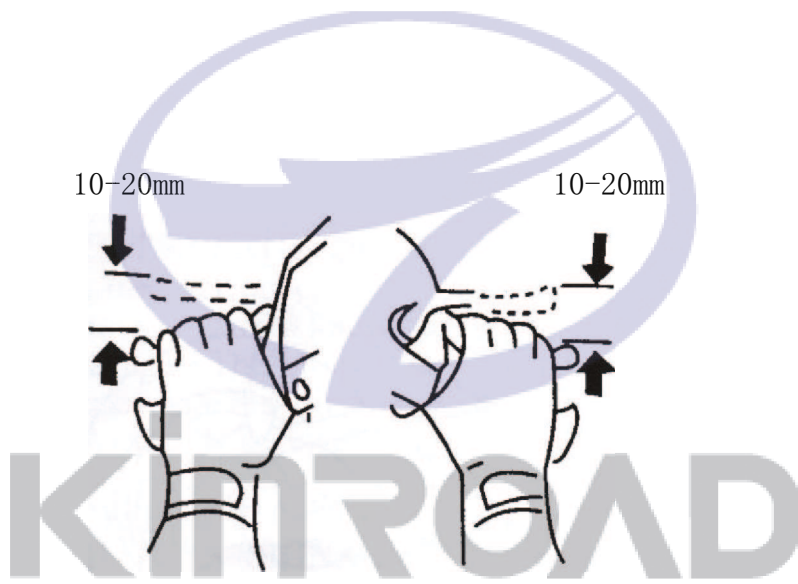

please refer to page 31 to adjust me brake lever play.

### FUNCTION OF THE BRAKES.

Check the front and rear brakes . function separately by drive on the dry road with low speed.

If the function of the brakes is not good, please refer to page 31 about brake shoe corrosion.

### CHECK THE TIRES

#### PRESSURE OF THE TIRES

Check pressure with pressure meter when they anr cool.



Tire pressure: front :175KPa

Rear :225Kpa

If the tires are abnormal, please go to dealers service station or replace them.

### CHECK THE AIR CLEANER ELEMENTS

Check if it prevents air going through by the dirty air cleaner elements.

#### **!CAUTION**

- 1.If the air cleaner elements are installed completely, it will affect the engine by dirt going into.
- 2.No water should go into it when washing the motorcycle.

### CHECK THE FLUID VOLUME OF THE BATTERY

This battery need not maintaining.

Need not check or add battery fluid.

#### **!CAUTION**

1. Do not pull off the seal plug since it is closed type.

2 Store the battery outside your motorcycle if you will not drive it for long time. If store it in the motorcycle you should shut Off the negative terminal.

### CHECK THE TRANSMISSION LEAKAGE

Check the transmission to see if there is oil leakage

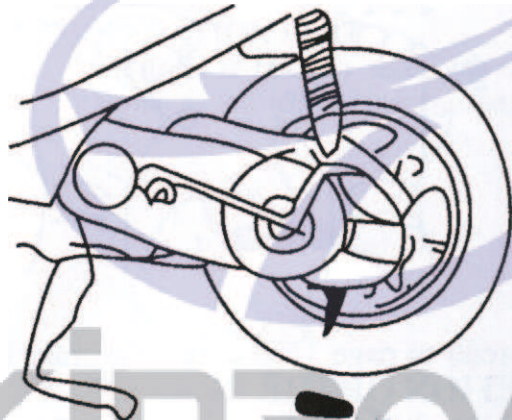

If the transmission leaks oil please go to KINROAD service station.

### CHECK THE LUBRICANT OF THE ENGINE

Check the oil pump and the oil tank to see if there is on leakage. If there is oil leakage please ask KINROAD dealer to check and maintain it

### CHECK THE LEVEL OF OIL OF THE ENGINE

Take off the cover to check if the oil in the oil tank is enough. If the oil is not enough, please add the special 4 stroke oil.

### CHECK LEAKAGE OF THE FUEL

Check the fuel tank, the fuel tank valve, the line and the carburetor to see if there is gasoline leakage. The oil line is worn or not. If the fuel leaks and the oil line is abnormal, go to the dealers service station to check.

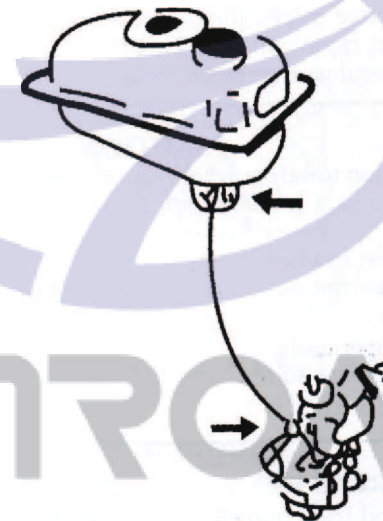

## CHECK THE FUNCTION OF THE LIGHTS & THE TURN SIGNAL INDICATOR

1. Check the lights with the head light, turn signals and the tail light.

2. Check the lightness and direction of the lights by making the light towards the wall

3. Start the turning indicator to check if it flashes 60—120 times in one minute.

4. Check covers of every light to see if there are some damages and loose places.

## CHECK THE LUBRICANT STATUS OF THE MOTORCYCLE

Check if the lubricant oil is enough of every part Of the motorcycle.

## SIMPLE MAINTANCE METHODS

After the above inspections, you should do some other simple adjustments replacements. This manual will give some common and useful maintenance methods.

### **!CAUTION**

Pay attention to safety when you maintain your motorcycle.

1. select a safe place which is flat, Wide and no dangers around.

2. Maintain it when it stops.

3 place the motorcycle on the center stand when maintaining.

4. Use proper tools.

5. Pay attention to the heat of the engine and the exhaust pipe.

## FRONT& REAR BRAKE ADJUSTMENT

the rear and front brake lever play measured at the end of the levers should be 10-20mm

After adjusting the play, check that there is no dragging when turning rear wheel with the wheel off the ground and that there is enough clearance between the rear brake lever and grip when the lever is tightly squeezed.

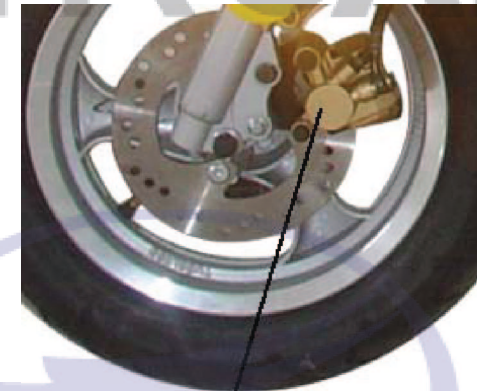

front brake

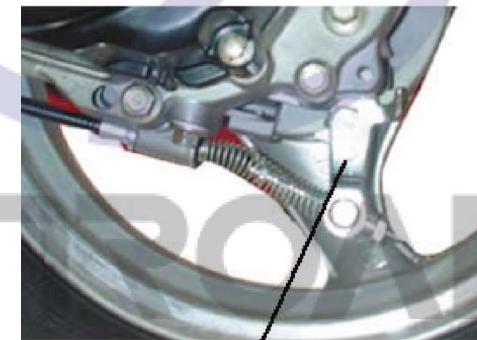

rear brake

### **!CAUTION**

Make the pin in the concave part of the adjuster otherwise, the clearance between the rear brake lever and grip will change when driving and it is very dangerous.

### **!CAUTION**

Replace the brake shoe if the marked continuous line is out of the limits when you take the brake lever tightly.

### **CORROSION OF THE BRAKE SHOE**

To know the corrosion status of the brake shoe . please inspect the places as the picture shows . Press the brake lever to the end . if the indicator shows that it is out the using limits, please go to the dealer' s service station to replace it.

### **REPLACE THE FUSE**

Turn the ignition switch to OFF to check if the fuse is complete, replace the fuse if it is blown.

The fuse is on the terminal of the battery, the standard current flow is 15 A.

### **INSTALL AND ASSEMBLE THE FUSE**

Take the terminal from the battery, and take off the fuse from the terminal.

### **MAIN POINTS**

Don' t touch the central part of the terminal after you take it down from the battery.

### **!CAUTION**

- 1.Always be sure to replace the blown fuse with the correct amperage fuse.
- 2.Using super amperage fuse will lead to heat or damage of the lines.
- 3.If the spare fuse installed blows in a short period of time, please try to find other cause, replace fuse after you have solve these causes.
- 4.Avoid water going into the fuse box when washing your motorcycle.

### **CLEAN THE TERMINAL OF BATTERY**

- 1.Wash the terminal with warm water when there are white powder on it, if it is badly corrosive, use metal brush.

2. Add some solid lubricant to the terminal when in—stalling it.



### **!CAUTION**

This motorcycle uses 12V—closed battery which need not check the liquid and add water.

### **PAY MUCH ATTENTION TO THE FOLLOWS:**

1. It cannot use unclosed battery.
2. The battery has been charged and added battery liquid, you need not check the level of the liquid or add water
3. Please use the special closed charger when charging.
4. Charge the battery every 6 months when it is used for a long time.
5. If you use other charger except for the closed battery , obey the following rules to prevent overcharging standard: 0.25A\* 8hours

Fast charge is forbidden.

### **PAY ATTENTION TO USING THE BATTERY**

The battery can have flammable gas, if it is not used correctly, injures and damages will happen.

1. Fire is forbidden , short circuit should be prevented, and smoke and other fire should be far from it.
2. Charge the battery in a ventilating place It is easily explosive in a closed place.
3. No intensive strike such as falling down.

### **EMERGENCY METHODS**

If your skin or cloth has touched the battery liquid, wash with water immediately, If your eyes have it, wash with water first, then go to the hospital.

### **WASH THE AIR CLEANER ELEMENT**

1. Disassemble the air cleaner element:
2. Wash the air cleaner element with non-flammable cleaning solvent and dry it completely.
3. Immerse the air cleaner element in a pool of clean motor oil and squeeze the oil off the air cleaner element to make it slightly wet with the oil.
4. Re-assemble the air cleaner element,

### **!CAUTION**

1. Gasoline and low ignition-point solvent is easily flammable, so please not use them when washing the air cleaner element.
2. Uncomplete assemblage will affect driving so

make sure to assemble the air cleaner element fixed.

3. Avoid water entering the air cleaner element when washing the motorcycle.

4. A torn air cleaner element must be replaced with a new one.

#### **PARTS NEED PERIODICALLY REPLACEMENT**

With driving your motorcycles, sometimes you can not judge some parts which can be used longer or not without external changes. Under this case, you must replace some important parts periodically.

To ensure your safe and comfortable driving, we hope you can replace these parts periodically. For example:

1. brake line: every 2 years

2. fuel hoses: every 4 years

3. oil for transmission case: every 1000 km When you replace parts, please buy them from motorcycle dealers.



KINROAD



KINROAD

KINROAD

## SPECIFICATIONS

	125CC		125CC
Overall length	1880mm	Cylinder bore × stroke	52.4×57.8
Overall width	685mm	Compression ratio	9.2:1
Overall height	1180mm	Output(max)	4.5kw/7000r/min
Wheelbase	1300mm	Torque(max)	6.5N.m/5500r/min
Dead weight	100kg	Idling speed	1500r±100r/min
Payload	150kg	Displacement of cylinder	124.0 ml
Front wheel	120/70-12	Spark plug	D8TC
Rear wheel	120/70-12	Spark plug gap	0.6-0.8mm
Speed(max)	75km/h	Gap of air valve	Inlakevalve:0.05mm
Braking distance	≤7m(30km/h)		Exhaust valve:0.08mm
Climb ability	≥18°	Ground clearance	150mm
Capacity of gasoline tank	5.5L	Ignition means	CDI
Transmission ratio			
Maximum transmission ratio	22.76		
Minimum transmission ratio	7.41		
Final reduction			



# ELECTRICAL DIAGRAM

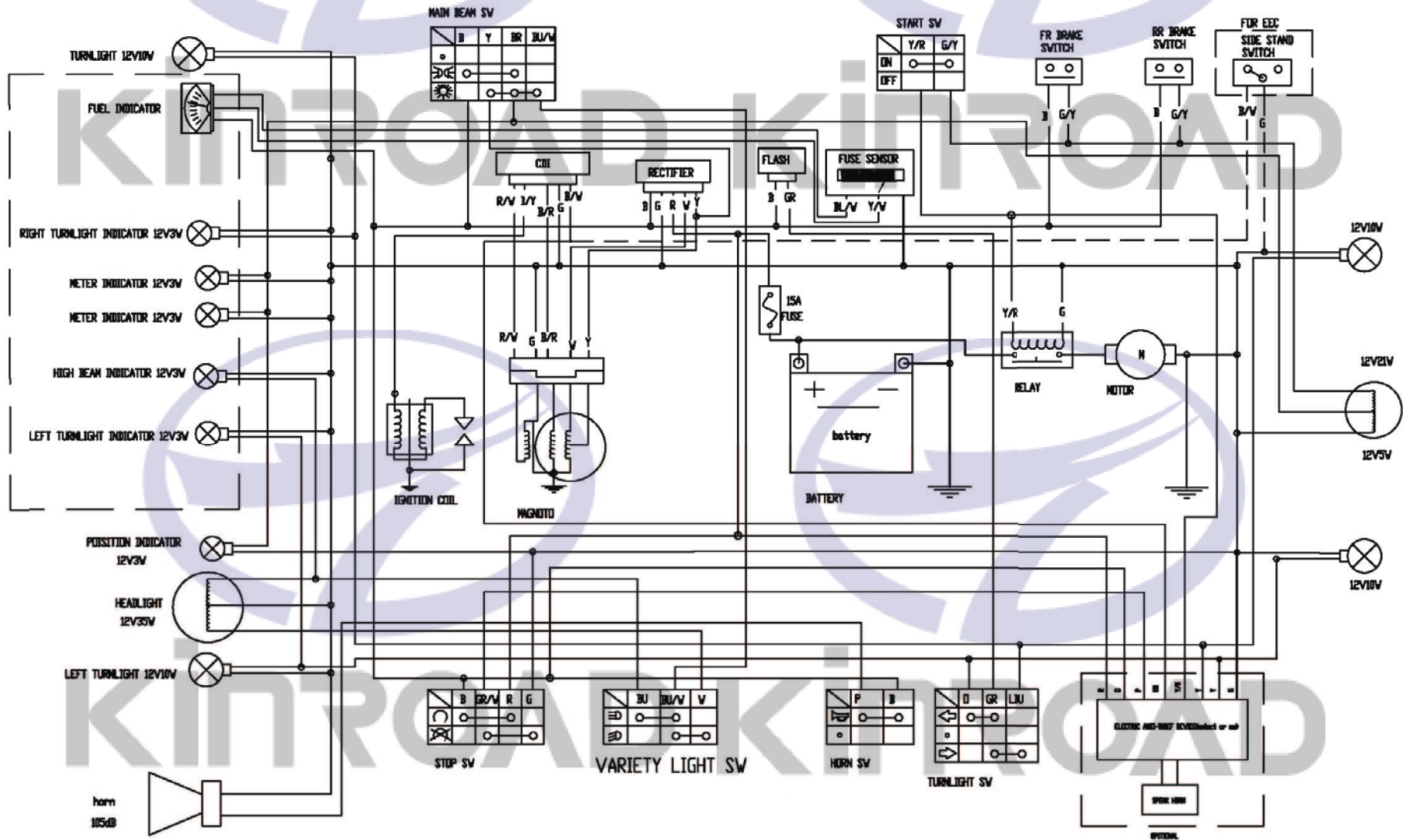

GREEN: G      BLACK: B      LIGHT BLUE: LBU  
 YELLOW: Y      PINK: P      LIGHT GREEN: LG  
 RED: R      GREY: GR      BLUE: BU